

# Conceptual Physics

## 11<sup>th</sup> Edition

PAUL G. HEWITT

### Chapter 27: COLOR

# This lecture will help you understand:

- Color in Our World
- Selective Reflection
- Selective Transmission
- Mixing Colored Light
- Mixing Colored Pigments
- Why the Sky Is Blue
- Why Sunsets Are Red
- Why Clouds Are White
- Why Water Is Greenish Blue

# Color in Our World

## Color

- Physiological experience
- In the eye of the beholder

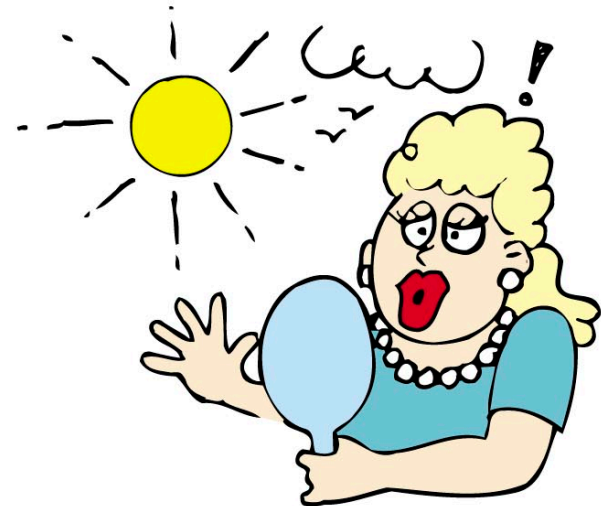

# Color in Our World

Color we see depends on frequency of light.

- Lowest frequency—perceived as red
- In between lowest and highest frequency—perceived as colors of the rainbow (red, orange, yellow, green, blue, indigo, violet)
- Highest frequency—perceived as violet
- Beyond violet, invisible ultraviolet (UV)

# Color

## CHECK YOUR NEIGHBOR

What can the human eye not see? 

- A. Infrared radiation
- B. Ultraviolet radiation
- C. Both A and B.
- F. Neither A nor B.

# Color

## CHECK YOUR ANSWER

What can the human eye not see?

- A. Infrared radiation
- B. Ultraviolet radiation
- C. Both A and B.**
- F. Neither A nor B.

# Selective Reflection

## Selective reflection

- We see the color of a rose by the light it reflects.

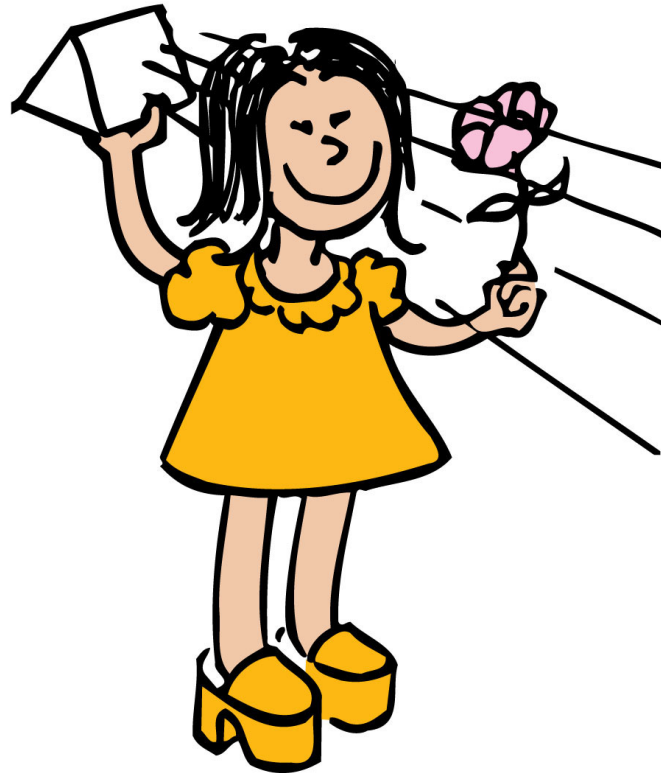

# Selective Reflection

Objects reflect light of some frequencies and absorb the rest.

- Rose petals absorb most of the light and reflect red.
- Objects that absorb light and reflect none appear black.
- Objects can reflect only those frequencies present in the illuminating light.



a



b

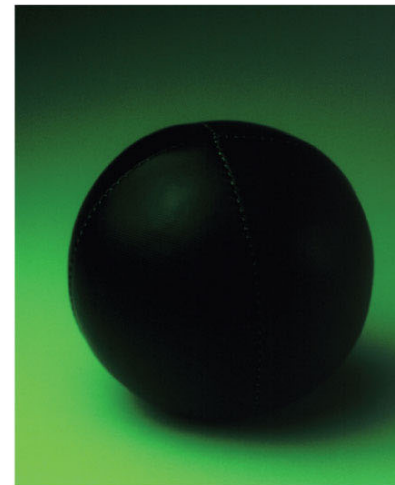

c



# Selective Transmission

Color of transparent object depends on color of light it transmits.

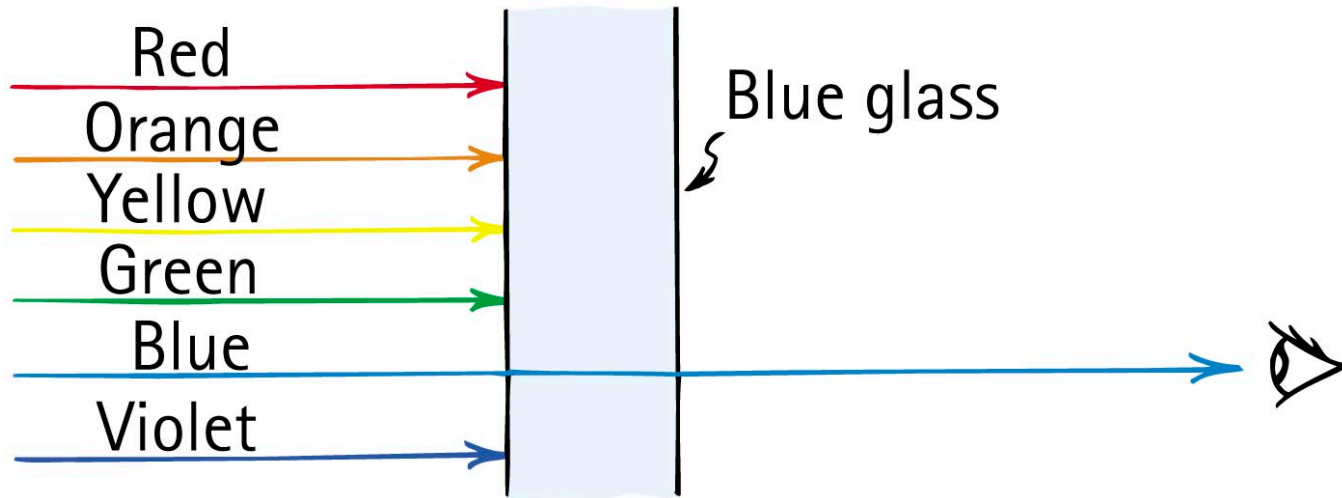

- Colored glass is warmed due to the energy of absorbed light illuminating the glass.

# Mixing Colored Light

## Mixed colored lights

- Distribution of solar frequencies is uneven.
  - Most intense in yellow-green portion (where our eyes are most sensitive)

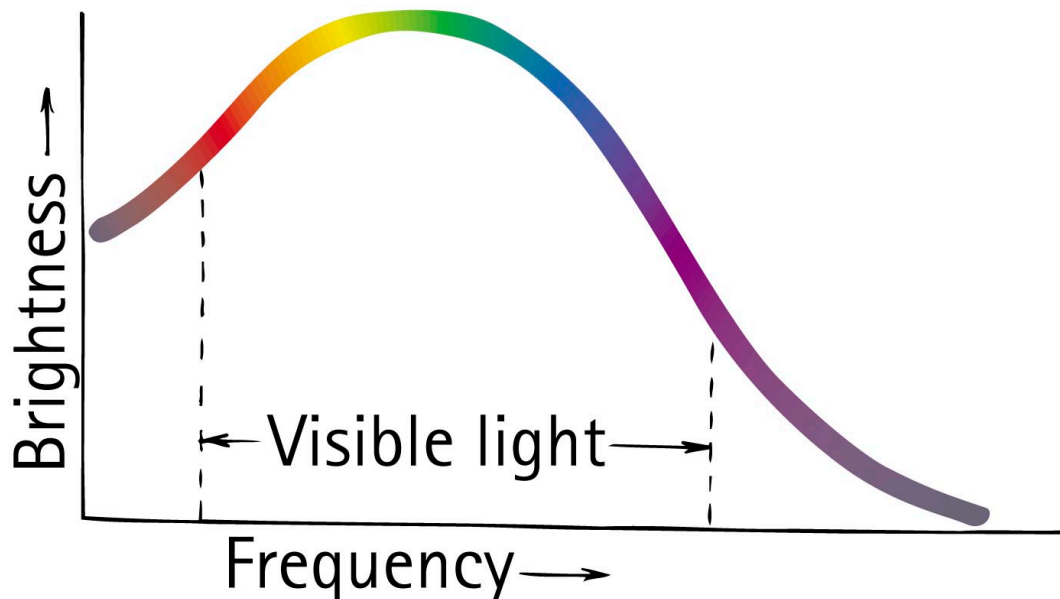

# Mixing Colored Light

Radiation curve divides into three regions that match the color receptors in our eyes.

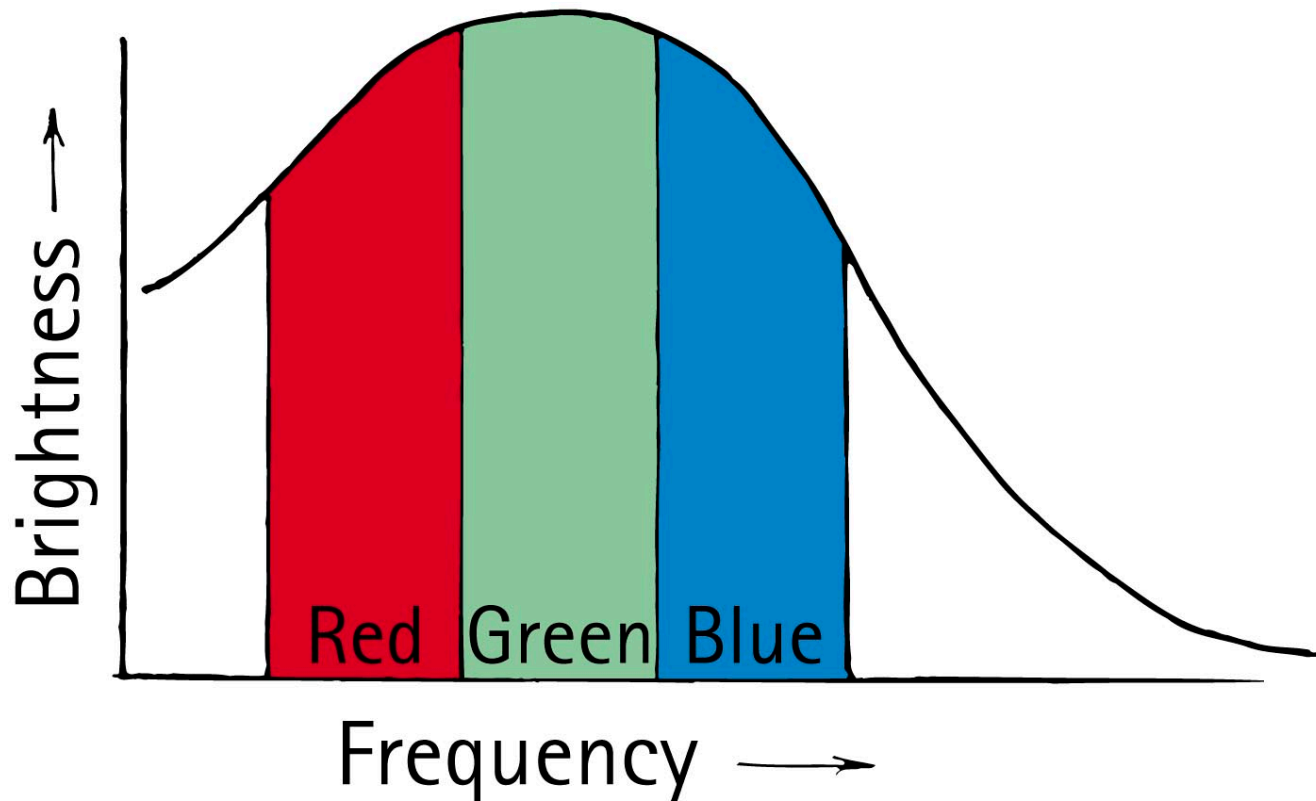

# Mixing Colored Light

Additive primary colors:

- Red, green, and blue
- Produce any color in the spectrum

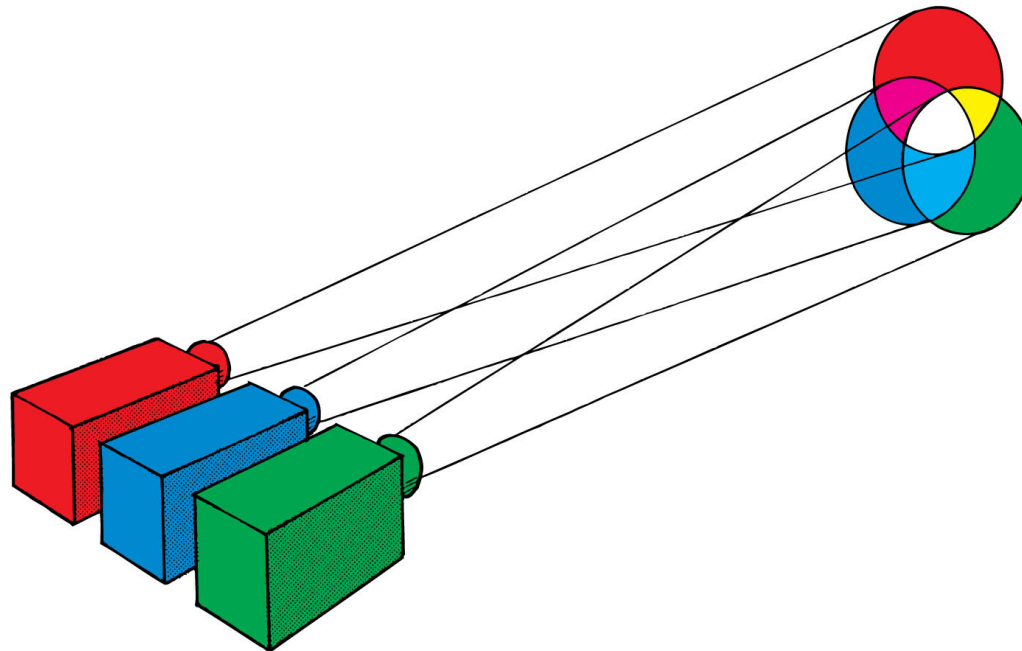

# Mixing Colored Light

## CHECK YOUR NEIGHBOR

Red, green, and blue light overlap to form 

- A. red light.
- B. green light.
- C. blue light.
- F. white light.

# Mixing Colored Light

## CHECK YOUR ANSWER

Red, green, and blue light overlap to form

- A. red light.
- B. green light.
- C. blue light.
- F. white light.**

# Mixing Colored Light

## CHECK YOUR NEIGHBOR

When the color yellow is seen on your TV screen, the phosphors being activated on the screen are

- A. mainly yellow.
- B. blue and red.
- C. green and yellow.
- F. red and green.

# Mixing Colored Light

## CHECK YOUR ANSWER

When the color yellow is seen on your TV screen, the phosphors being activated on the screen are

- A. mainly yellow.
- B. blue and red.
- C. green and yellow.
- F. red and green.**



# Mixing Colored Light

## CHECK YOUR NEIGHBOR

A blue object will appear black when illuminated with 

- A. blue light.
- B. cyan light.
- C. yellow light.
- F. magenta light.

# Mixing Colored Light

## CHECK YOUR ANSWER

A blue object will appear black when illuminated with

- A. blue light.
- B. cyan light.
- C. yellow light.**
- F. magenta light.

# Mixing Colored Light

## Subtractive primary colors

- Combination of two of the three additive primary colors:
  - red + blue = magenta
  - red + green = yellow
  - blue + green = cyan

# Mixing Colored Light

The shadows of the golf ball are subtractive.

- Magenta (opposite of green)
- Cyan (opposite of red)
- Yellow (opposite of blue)

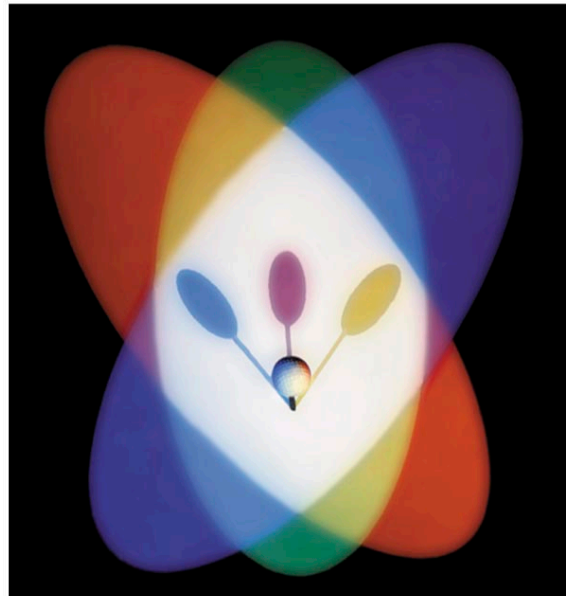

# Mixing Colored Light

Subtractive primaries are complementary to additive primaries.

- magenta + green = white = red + blue + green
- yellow + blue = white + red + green + blue

Example: color printing



# Mixing Colored Light

## CHECK YOUR NEIGHBOR

A red rose will *not* appear red when illuminated only with 

- A. red light.
- B. orange light.
- C. white light.
- F. cyan light.

# Mixing Colored Light

## CHECK YOUR ANSWER

A red rose will *not* appear red when illuminated only with

- A. red light.
- B. orange light.
- C. white light.
- F. cyan light.**

# Mixing Colored Pigments



(a)



(b)



(c)



(d)



(e)



(f)

Only three colors of ink (plus black) are used to print color photographs—(a) magenta, (b) yellow, (c) cyan, which when combined produce the colors shown in (d). The addition of black (e) produces the finished result (f).



# Mixing Colored Pigments

- The subtractive primary colors are cyan, yellow, and magenta.
- When white light passes through overlapping sheets of these colors, light of all frequencies is blocked (subtracted) and we have black.
- Where only cyan and yellow overlap, light of all frequencies except green is subtracted.
- Various proportions of cyan, yellow, and magenta dyes will produce nearly any color in the spectrum.

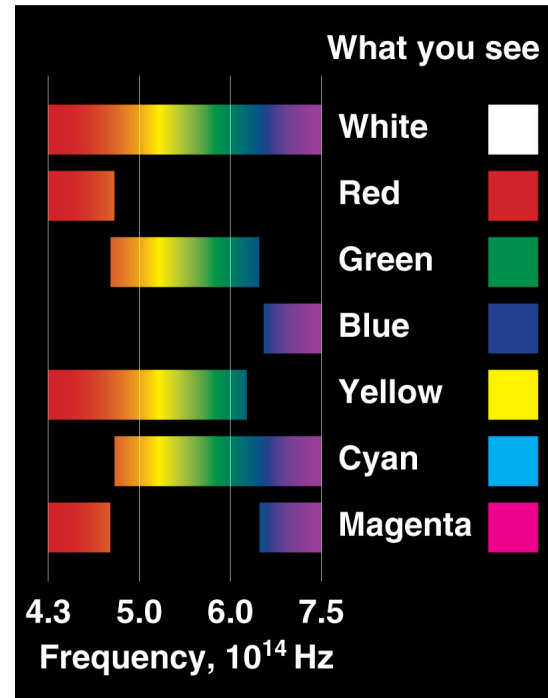

# Why the Sky Is Blue

## Why the sky is blue

- Results of selective scattering of smaller particles than the wavelength of incident light and resonances at frequencies higher than scattered light
- The tinier the particle, the higher the frequency of light it will re-emit.

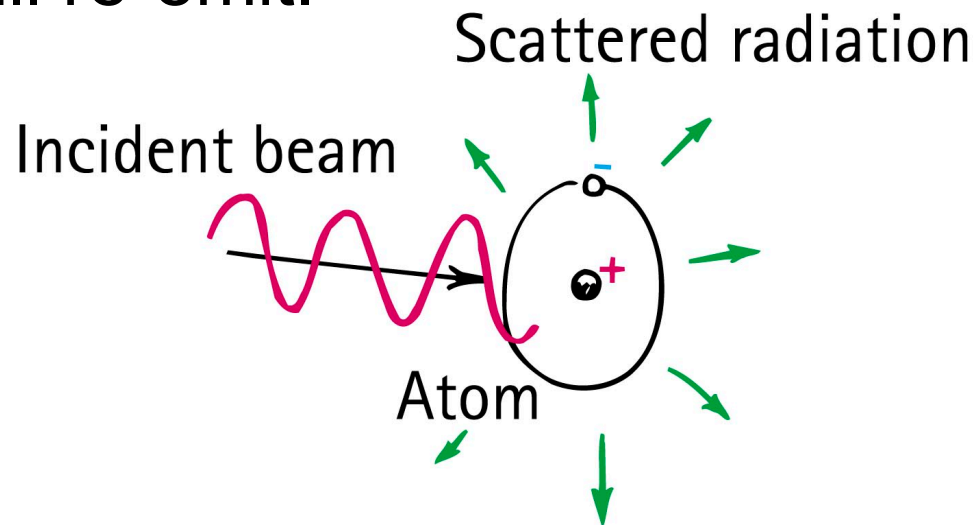

# Why the Sky Is Blue

## Why the sky is blue (continued)

- Due to selective scattering
- Blue scattered light predominates in our vision.
- Varies in different locations under various conditions:
  - Clear dry day—much deeper blue sky
  - Clear, humid day—beautiful blue sky
  - Lots of dust particles and larger molecules than nitrogen and oxygen in the atmosphere—less blue sky with whitish appearance
  - After heavy rainstorm (washing away of airborne particles)—deeper blue sky

# Why the Sky Is Blue

## CHECK YOUR NEIGHBOR

A white sky is evidence that the atmosphere contains 

- A. predominantly small particles.
- B. predominantly large particles.
- C. a mixture of particle sizes.
- F. pollutants.

# Why the Sky Is Blue

## CHECK YOUR ANSWER

A white sky is evidence that the atmosphere contains

- A. predominantly small particles.
- B. predominantly large particles.
- C. a mixture of particle sizes.**
- F. pollutants.

# Why Sunsets Are Red

Light that is least scattered is light of low frequencies, which best travel through air.

- Red
- Orange
- Yellow

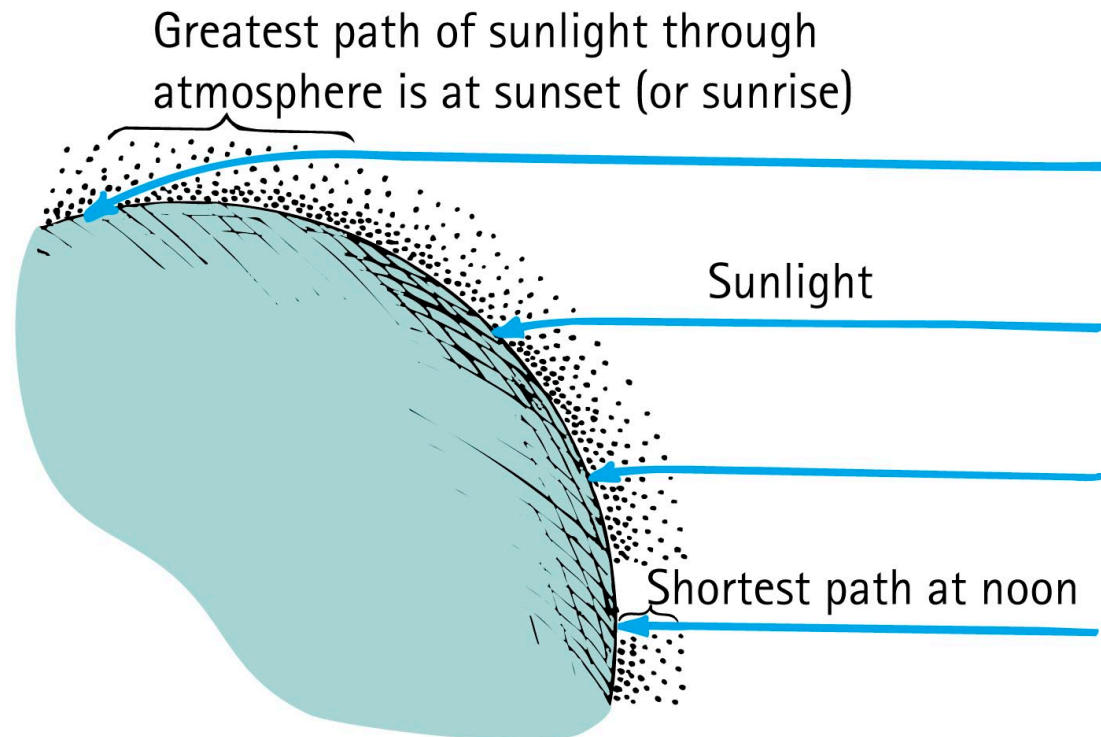

# Why Sunsets Are Red

## CHECK YOUR NEIGHBOR

A variety of sunset colors is evidence for a variety of 

- A. elements in the Sun.
- B. apparent atmosphere thickness.
- C. atmospheric particles.
- F. primary colors.

# Why Sunsets Are Red

## CHECK YOUR ANSWER

A variety of sunset colors is evidence for a variety of

- A. elements in the Sun.
- B. apparent atmosphere thickness.
- C. atmospheric particles.**
- F. primary colors.



# Why Sunsets Are Red

## CHECK YOUR NEIGHBOR

If molecules in the sky scattered orange light instead of blue light, sunsets would be

- A. orange.
- B. yellow.
- C. green.
- F. blue.

# Why Sunsets Are Red

## CHECK YOUR ANSWER

If molecules in the sky scattered orange light instead of blue light, sunsets would be

- A. orange.
- B. yellow.
- C. green.
- F. blue.**

*Explanation:*

Of the colors listed, blue is closest to being the complementary color of orange.

# Why Clouds Are White

## Clouds

- Clusters of various sizes of water droplets



# Why Clouds Are White

Size of clusters determines scattered cloud color.

- Tiny clusters produce bluish clouds.
- Slightly large clusters produce greenish clouds.
- Larger clusters produce reddish clouds.
- Overall result is white clouds.
- Slightly larger clusters produce a deep gray.
- Still larger clusters produce raindrops.

# Why Water Is Greenish Blue

- Water molecules resonate somewhat in the visible red, which causes red light to be a little more strongly absorbed in water than blue light.
- Red light is reduced to one-quarter of its initial brightness by 15 meters of water. There is very little red light in the sunlight that penetrates below 30 meters of water.
- When red is removed from white light, the complementary color of red remains: cyan—a bluish-green color.



# Why Water Is Greenish Blue

- The intriguingly vivid blue of lakes in the Canadian Rockies is due to scattering.
- The lakes are fed by runoff from melting glaciers that contain fine particles of silt, called rock flour, which remain suspended in the water.
- Light scatters from these tiny particles and gives the water its eerily vivid color.

